

EE5390: Analog Integrated Circuit Design; Homework 4

Due: 20 April 2012

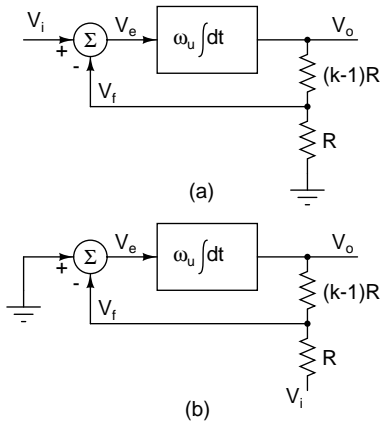

Figure 1: Problem 1

- Fig. 1(a) shows the amplifier studied in class. Fig. 1(b) shows the same system with the input applied at a different place. Calculate the dc gain, the -3dB bandwidth, and the gain bandwidth product of the system and compare them to the corresponding quantities in Fig. 1(a). Also compare the loop gains. Remark on conventional wisdom such as “constant gain bandwidth product”, “closed loop bandwidth = unity gain frequency/closed loop dc gain”. What is the reason for the discrepancy?

Draw an equivalent block diagram of Fig. 1(b) such that the classical form of feedback (sensed error integrated to drive the output) is clearly obvious (Hint: compute the error voltage V_e).

- Fig. 2(a) and Fig. 2(b) shows amplifiers which realize gains of k and $-k$ respectively with ideal opamps. Compare the following parameters of the two circuits. Model the opamp as an integrator ω_u/s .

- Input impedance
- Bandwidth

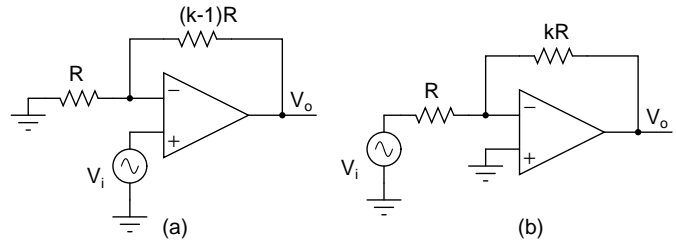

Figure 2: Problem 2

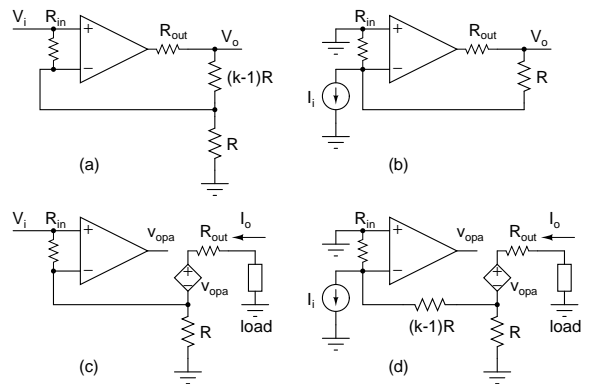

Figure 3: Problem 3: (a) VCVS, (b) CCVS, (c) VCCS, (d) CCCS

- Differential ($V_+(s) - V_-(s)$) and common mode ($(V_+(s) + V_-(s))/2$) input voltages of the opamps

Assuming that the sign of the gain is unimportant in your application, what would make you choose one over the other? Is there any reason to choose Fig. 2(b) at all?

- Fig. 3 shows the four types of controlled sources using an opamp. Model the opamp as an integrator ω_u/s . For each of these, calculate the transfer ratio (output/input), input impedance, and output

impedance at (a) dc, and (b) an arbitrary frequency ω . For (b), set $R_{out} = 0$ when calculating the input impedance and $R_{in} = \infty$ while calculating the output impedance. What happens to these three quantities at high frequencies in each case?

4. The loop gain $L(s)$ of a system with N extra poles is given by

$$L(s) = \frac{\omega_{u,loop}}{s} \frac{1}{\sum_{m=0}^N a_m s^m}$$

$a_0 = 1$. What does the loop gain step response (inverse laplace transform of $L(s)/s$) look like after an initial transient period? Give your answer in terms of the poles of the additional factor (Hint: Split $L(s)$ into a sum of two parts, one of which is $\omega_{u,loop}/s$)

5. Due to some parasitic effects, an opamp has a transfer function with an extra pole p_2 ($\omega_u/s(1 + s/p_2)$ instead of ω_u/s). This is used to realize an amplifier with a closed loop dc gain k . Instead of the step response, the criterion here is the bandwidth. Find the conditions to maximize the bandwidth without the closed loop gain increasing above k for any frequency (This condition is known as maximal flatness, and the mathematical condition is to have $d^n/d\omega^n |H(j\omega)|^2 = 0$, $n = 1, 2, \dots$ for as large an n as possible). To avoid mess, assume a general form of the second order transfer function, evaluate the damping factor for maximal flatness, and substitute the values from the transfer function of the amplifier. How does it compare to a critically damped system?

Appreciating approximations: Approximations are key to understanding anything complicated. Exact expressions, even when possible, may be too complicated to give any insight to the problem. Approximating is not the same as being sloppy. On the contrary, a greater understanding of the problem is required to judiciously use approximations than plug in the whole formula (e.g. see the quadratic eq. example below).

Evaluate the conditions for 1% and 10% accuracy for the quantities mentioned using the approximations below.

1. You are required to calculate $\sqrt{1+x}$ and you approximate it by $1+x/2$.
2. You are required to solve the quadratic equation ax^2+bx+c and you approximate the roots by $-b/a$, $-c/b$. This works for widely separated real roots. How widely do they have to be separated (ratio)?
3. You have a two stage amplifier in feedback loop with loop gain $L(s) = A_{0,loop}/(1+s/p_1)(1+s/p_2)$, $p_2 > p_1$, $p_1 = \omega_{u,loop}/A_{0,loop}$ and you approximate it by moving the lower frequency pole to the origin— i.e. use the transfer function $L(s) \approx (\omega_{u,loop}/s)(1+s/p_2)$ instead. You have to calculate (a) natural frequency ω_n , (b) damping factor ζ . Compare the expressions for the two quantities. Calculate $A_{0,loop}$ to get the above errors (Assume $p_2 = 2\omega_{u,loop}$).