

EE5310: Analog Electronic Circuits

EE3002: Analog Circuits

Introduction

S. Aniruddhan

<https://courses.iitm.ac.in>

Department of Electrical Engineering
Indian Institute of Technology, Madras
Chennai, 600036, India

1 August 2017

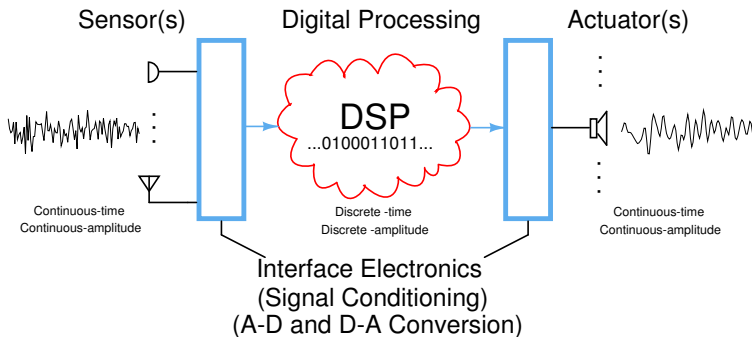

Picture: courtesy Shanthy Pavan

Analog circuits in modern systems on VLSI chips

- Analog to digital conversion
- Digital to analog conversion
- Amplification
- Signal processing circuits at high frequencies
- **Power management-voltage references, voltage regulators**
- **Oscillators**

The last two are found even on many “digital” ICs

Analog IC design in India

- Many companies starting analog centers
- Multinationals and Indian start ups
- Big demand for skilled designers
- Interesting and profitable activity 😊

Theory

- Small signal analysis of nonlinear systems
- Analysis of nonlinearity and frequency response
- Stabilization of feedback circuits

Design

- Amplifier topologies
- Biasing techniques

Course goals

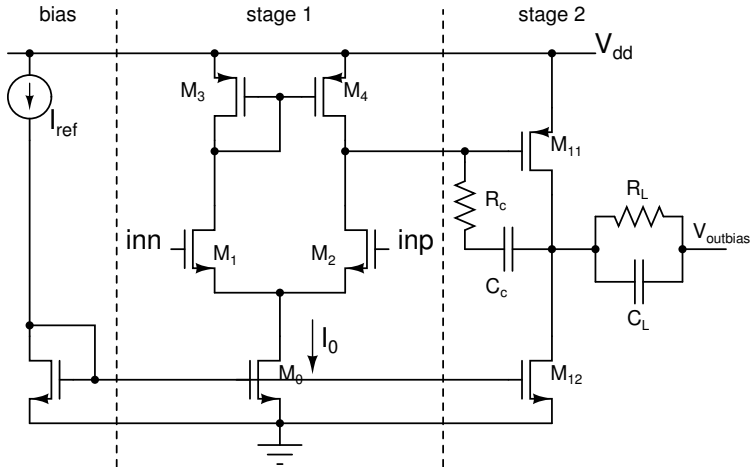

Course prerequisites

- Circuit analysis
 - Mesh, nodal analyses
 - RLC, linear dependent sources
- Laplace transforms, frequency response
- Differential equations

EE1101: Signals and Systems

EE2015: Electrical Circuits and Networks

EE2019: Analog Systems and Lab

Course contents

- Nonlinear circuits-incremental analysis
- Obtaining power gain; MOS transistor
- Amplifiers with MOS and BJTs
- Opamps, negative feedback, stability
- Applications: Active filter, voltage regulator

- EE5320: Analog IC Design
 - EE5321: Active Filter Design
 - EE5323: Advanced Electrical Networks
 - EE5325: Power Management Integrated Circuits
-
- EE6320: RF Integrated Circuits
 - EE6321: VLSI Data Conversion Circuits
 - EE6322: VLSI Broadband Communication Circuits
 - EE6323: Wireless System Design
 - EE6324:Phase-Locked Loops
 - EE6325: Advanced Power Management Systems

Course homepage

- IITM moodle: <https://courses.iitm.ac.in/>
- http://www.ee.iitm.ac.in/vlsi/ee3002_2017/start

Recorded lectures

- <http://www.ee.iitm.ac.in/~nagendra/videolectures/>
- Lectures recorded in the classroom
- KRK Rao foundation on Analog Design, June 2008: (Review of basic concepts: Network analysis, small signal analysis, Transistor models, Negative feedback)
- NPTEL—Prof. VGK Murti's *Networks and Systems*, and other courses on circuit analysis.

Text book

- None

Online course: Analog Circuits

- https://onlinecourses.nptel.ac.in/noc15_ee02/
- www.youtube.com/channel/UC5EaK1RFUtAm6t3HSb1b40w
- Search for “NOC15 July-Sep EE02” in youtube

References

- A. S. Sedra and K. C. Smith, *Microelectronic Circuits*, 5ed, Oxford University Press, 2004.
- Sergio Franco, *Design with operational amplifiers and analog ICs*, Tata McGraw Hill.
- Hayt and Kemmerly, *Engineering Circuit Analysis*, McGraw Hill, 6/e.
- B. P. Lathi, *Linear Systems and Signals*, Oxford University Press, 2 edition, 2004.
- N. Krishnapura, "Introduction to EE539",
<http://www.ee.iitm.ac.in/~nagendra/EE539/200801/handouts.html>

Logistics, etiquette and expectations

Logistics:

- E slot (We will follow the MTech calendar)
- Classroom: ESB127

Etiquette and expectations:

- Mobile phones off
- Don't enter the class if more than 5 minutes late
- **Must** solve problems given in classes

Must know or refresh

- Basic circuit analysis (nodal/mesh analysis)
- Small signal incremental analysis
- Bode plots
- Two port parameters
- Circuit analysis with Laplace transforms

(Links to recorded lectures on the webpage)

Evaluation

- 4 quizzes-50 to 60%
- End sem-40%
- Problem sets on the course website-up to 10%
 - Must attend. Marks based on number of problems solved completely.

Teaching assistants

Post any questions related to the course on the moodle forum
TAs will be at: DSD lab(ESB 122) or VLSI group labs(CSD 204,
206)
Office hours will be announced

For more advanced students

Simulate the circuits you see in class before the simulation assignments are posted

- <http://www.ee.iitm.ac.in/~nagendra/cadinfo.html>
- Online spice simulator at
<http://www.ngspice.com/index.php>

Build the circuits

- Breadboard, components, IE lab