

ANALOG SYSTEMS : PROBLEM SET 2

Problem 1

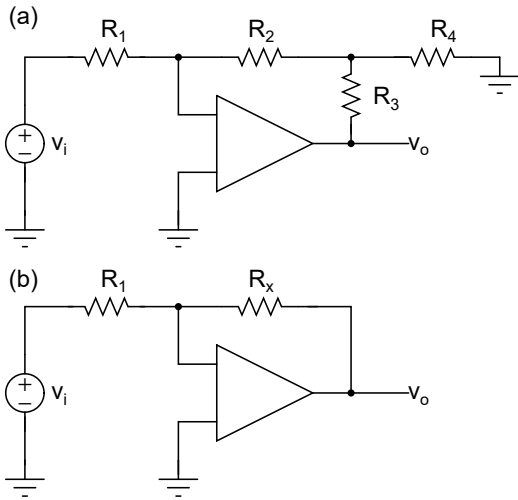

Figure 1: Circuits for Problem 1.

In the circuits above, determine the signs on the opamps for negative feedback operation, and determine v_o/v_i . When realizing a gain with a large magnitude, what might be the advantage of the circuit of (a) over that in (b)?

Problem 2

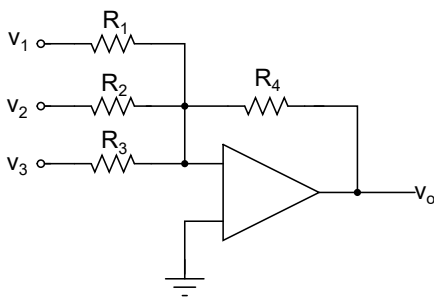

Figure 2: Circuit for Problem 2.

In the circuit above, determine the signs on the opamp to ensure negative feedback. Also determine v_o in terms of v_1 , v_2 and v_3 .

Problem 3

In the figure, the opamp is operated with dual supplies of $\pm 10V$. The saturation limits of may be assumed to be

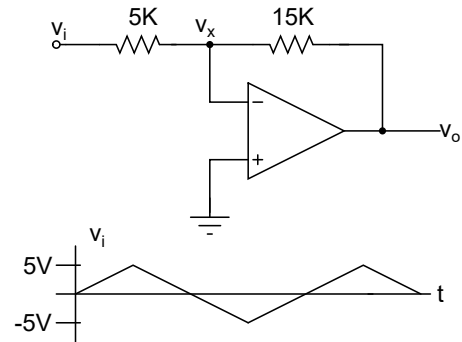

Figure 3: Circuit for Problem 3.

$\pm 9V$. The input to the amplifier is shown. Sketch the output and the voltage v_x at the virtual ground node. What is the maximum input amplitude that will ensure a distortion free output?

Problem 4

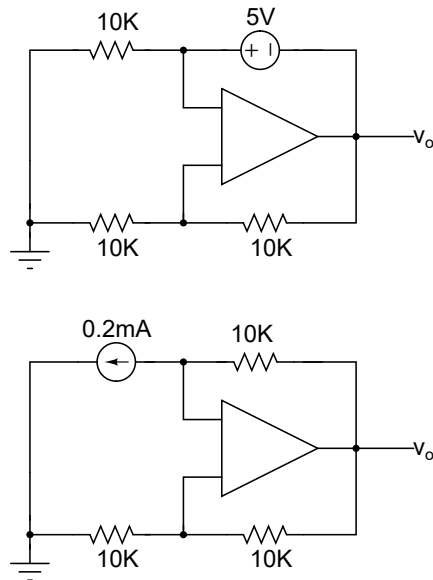

Figure 4: Circuits for Problem 4.

In the circuits above, mark the signs on the opamp for negative feedback operation, and determine v_o .

Problem 5

In the circuits above, mark the signs on the opamp for negative feedback operation, and determine v_o .

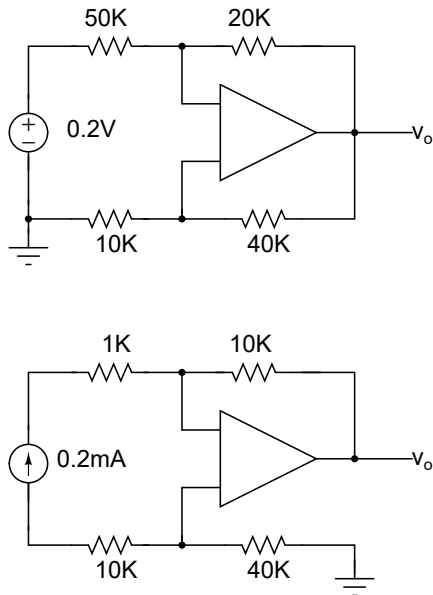

Figure 5: Circuits for Problem 5.

Problem 6

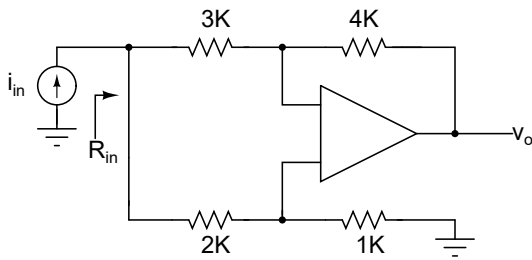

Figure 6: Circuits for Problem 6.

In the circuit above, mark the signs on the opamp for negative feedback operation, and determine v_o . Determine the input resistance looking in, as denoted by R_{in} .

Problem 7

In the circuit above, mark the signs on the opamp for negative feedback operation, and determine v_o in terms of v_1, \dots, v_6 .

Problem 8

In the circuit above, mark the signs on the opamp for negative feedback operation, and determine v_o .

Problem 9

In the circuit above, mark the signs on the opamp for negative feedback operation, and determine the Norton equivalent for the circuit looking across the load resistor R_L .

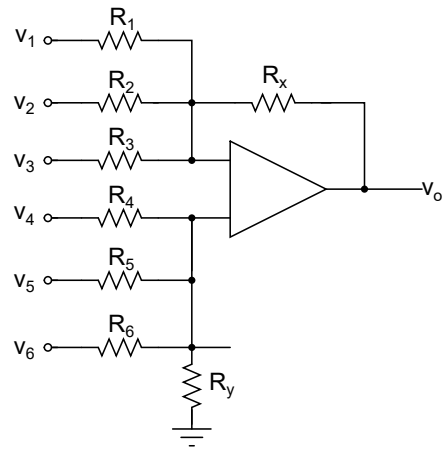

Figure 7: Circuit for Problem 7.

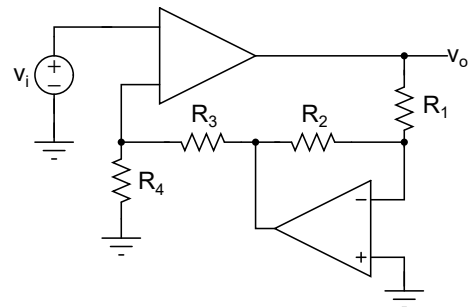

Figure 8: Circuit for Problem 8.

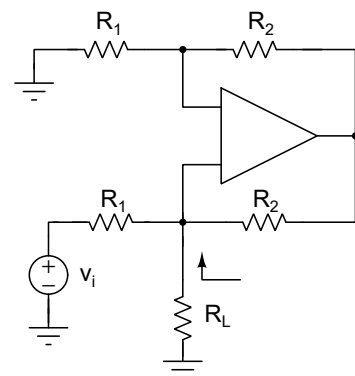

Figure 9: Circuit for Problem 9.

Problem 10

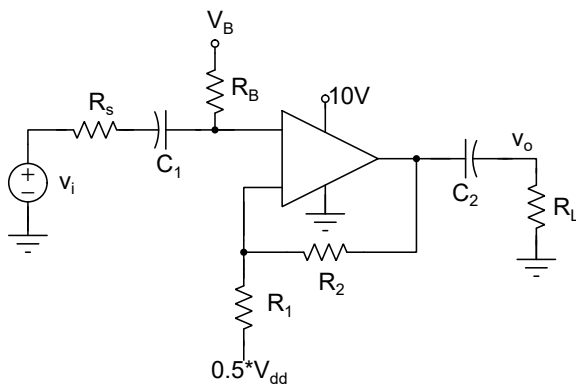

Figure 10: Circuit for Problem 10.

The circuit above shows an amplifier intended for audio applications. The lowest frequency of interest, therefore, is 20 Hz. The opamp is operated with a **single** supply. Assume $V_{DD} = 10$ V.

- Mark the signs on the opamp for negative feedback operation. Determine V_B so that no dc current flows through R_1 .
- $R_1 = 10$ K, $R_s = 50$ K and $R_L = 1$ K. $C_1 = 1$ μ F. Determine R_B so that the ac voltage across C_1 at the lowest frequency of interest is less than 1% of v_i .
- Determine C_2 so that the ac voltage across it at the lowest frequency of interest is less than 1% of the ac amplitude across the load resistor.
- Determine R_2 to achieve an ac gain of 50. Sketch the magnitude of the transfer function from v_i to v_o .
- Determine the largest input amplitude of a 1 kHz sinusoid that will result in a distortion free output. The opamp saturates if its output attempts to go to within 1 V of its supply rails.

Problem 11

This problem illustrates another aspect of negative feedback, namely pre-distortion. In the amplifier above, the opamp is non-ideal. We will consider two cases. In the first, the opamp's input characteristic is as shown in Fig. 11(a). Plot the error voltage v_e between the input terminals of the opamp as v_i is swept from $-v_{max}/n$ to v_{max}/n . Assume that $A/n \gg 1$.

In class we assumed that the opamp characteristic saturates abruptly. In reality, saturation occurs in a gentler fashion. An example is shown in Fig. 11(b). On the same graph as you plotted for the previous part, plot v_e as v_i is swept. What do you notice?

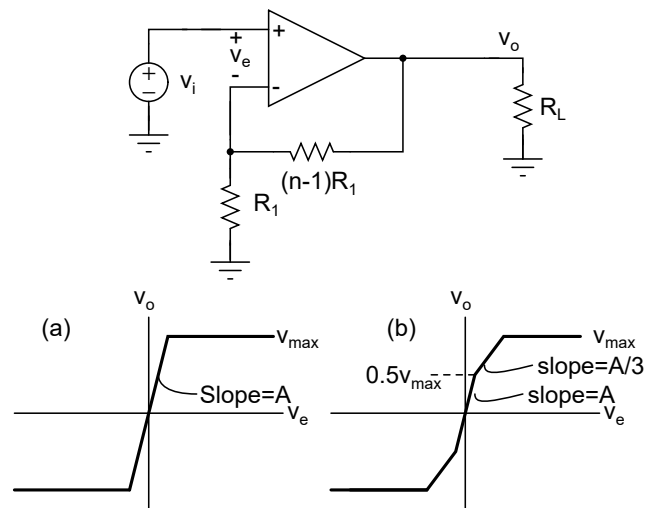

Figure 11: Circuit for Problem 11.

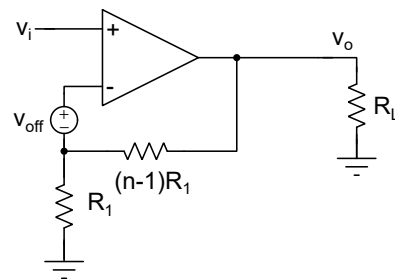

Figure 12: Circuit for Problem 12.

Problem 12

This circuit explores another non-ideality of an opamp, namely **offset**. In an ideal opamp, $v_o = Av_e$, with $A \rightarrow \infty$. In reality, it turns out that if the opamp does not saturate, its output can be expressed as $v_o = A(v_e - v_{off})$, with $A \rightarrow \infty$. Draw the characteristics of an ideal opamp assuming saturation, and that of the opamp with an offset voltage. What is the output dc offset of the amplifier of Fig. 12?

Problem 13

The figure above shows three different ways of achieving an amplifier with a gain of n^2 , where $n^2 \gg 1$. If $v_{off,1,2} = 0$ and the opamps have infinite gain, all three are equivalent. When the opamps have a finite gain A , the gains will deviate from the ideal value of n^2 . Determine the output offset voltage and gain in each of the three cases. Make suitable approximations, such as $1/(1+x) \approx 1-x$ for small x etc. Which of the amplifiers above is least tolerant of finite opamp gain? Which is the most tolerant?

Problem 14

In many precision sensing applications, amplifier offset can be (very) problematic. This problem illustrates the idea of **chopping**, which is one way of solving the offset problem. The amplifier's offset is modeled by v_{off} . The input u is multiplied by a square wave with 50% duty cycle, processed by the amplifier (whose gain is A). The output of the amplifier is multiplied by the same square wave, and passed through a low-pass filter. $p(t)$ has a fundamental frequency of f_c , as shown in Fig. 14. For the purposes of this problem, you can assume that the filter is ideal and has a cut-off frequency smaller than f_c .

Assuming u is dc, plot the signals at **(a)**, the amplifier output, **(b)** and at y . What is y/u ?

Repeat the exercise above assuming that the amplifier, in addition to offset, has finite bandwidth. For simplicity, assume that the transfer function of the amplifier is

$$A(s) = \frac{A_o}{1 + s\tau} \quad (1)$$

where $\tau f_c \ll 1$.

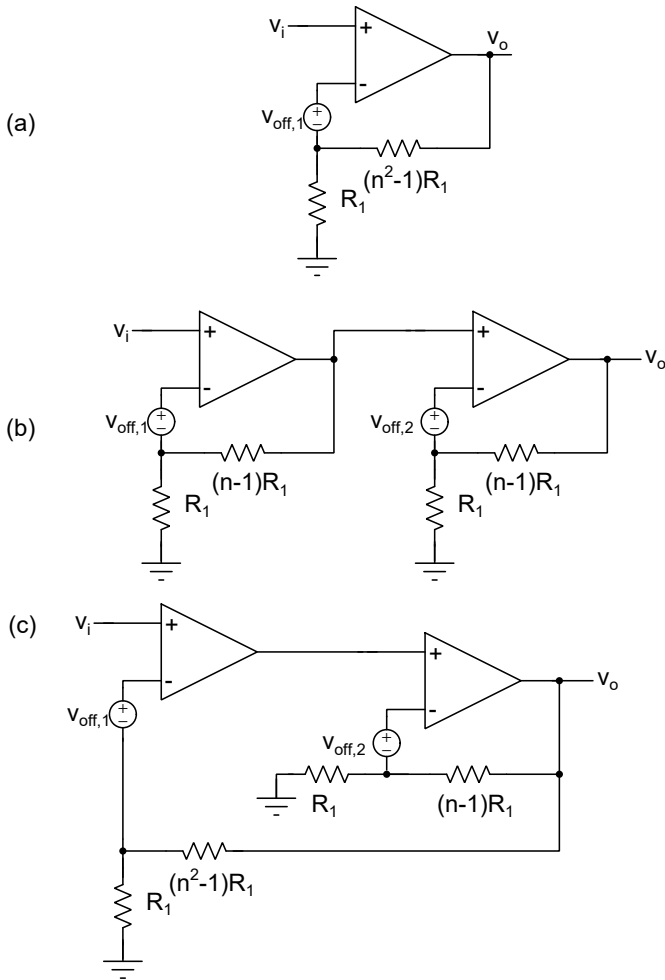

Figure 13: Circuit for Problem 13.

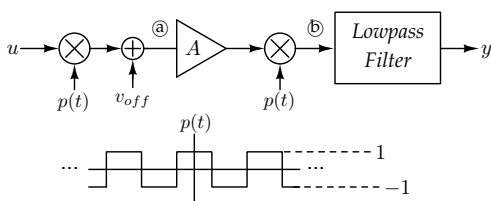

Figure 14: Circuit for Problem 14.

Problem 15

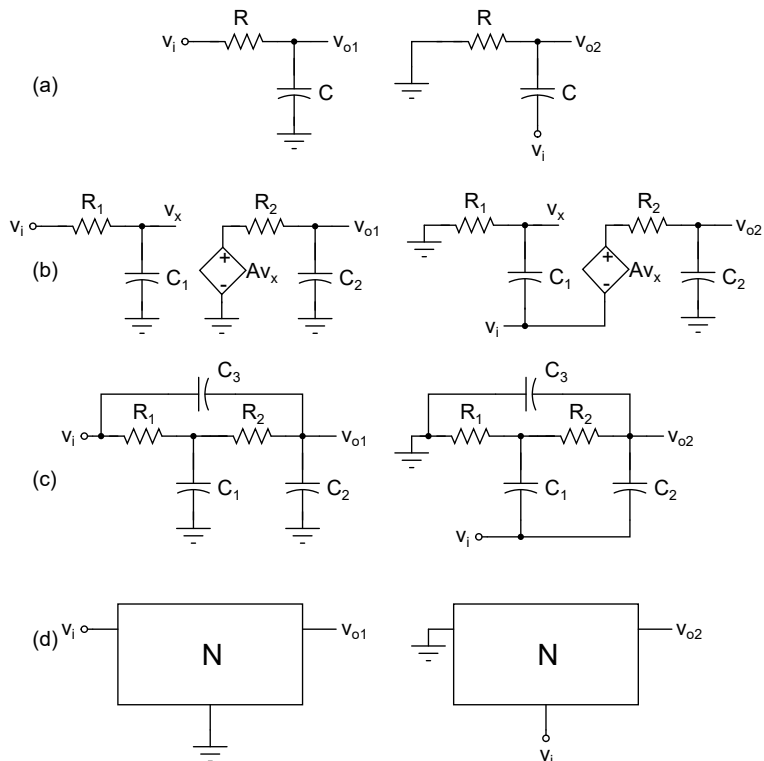

Figure 15: Circuit for Problem 15.

For each of the networks in parts (a), (b) and (c) above, determine $H_1(s) = V_{o1}(s)/V_i(s)$ and $H_2(s) = V_{o2}(s)/V_i(s)$. Is there a pattern you notice? Generalize it to an arbitrary linear network of Fig. 15(d).

Problem 16

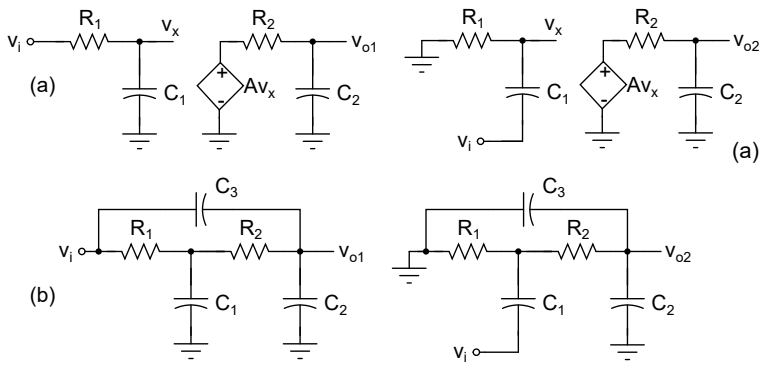

Figure 16: Circuit for Problem 16.

For each of the networks in parts (a), (b) above, determine $H_1(s) = V_{o1}(s)/V_i(s)$ and $H_2(s) = V_{o2}(s)/V_i(s)$. Does the pattern you noticed in the previous problem still hold?

Problem 17

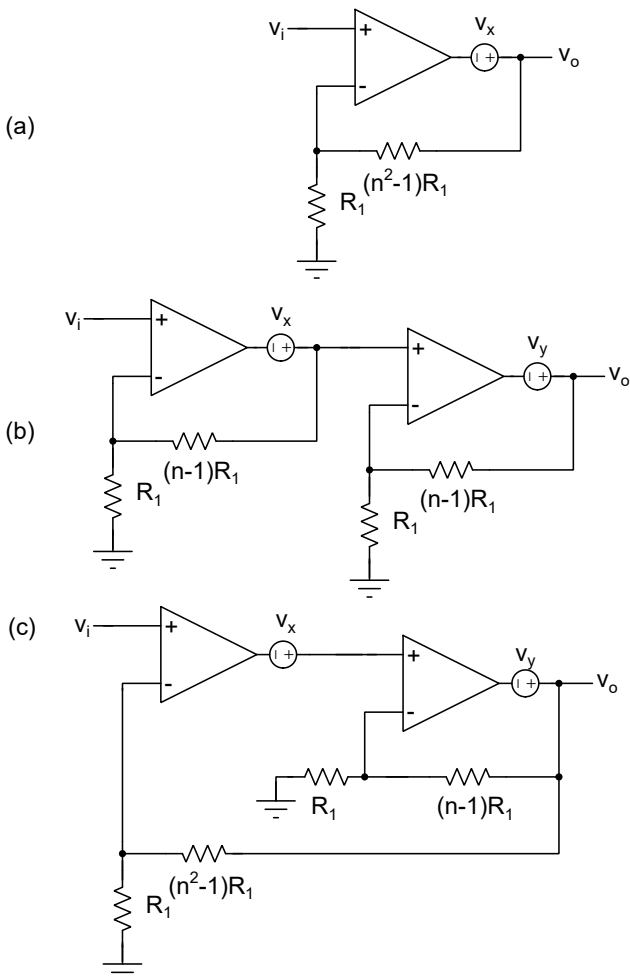

Figure 17: Circuit for Problem 17.

For each of the circuits above, the opamps are ideal. Determine v_o .

Problem 18

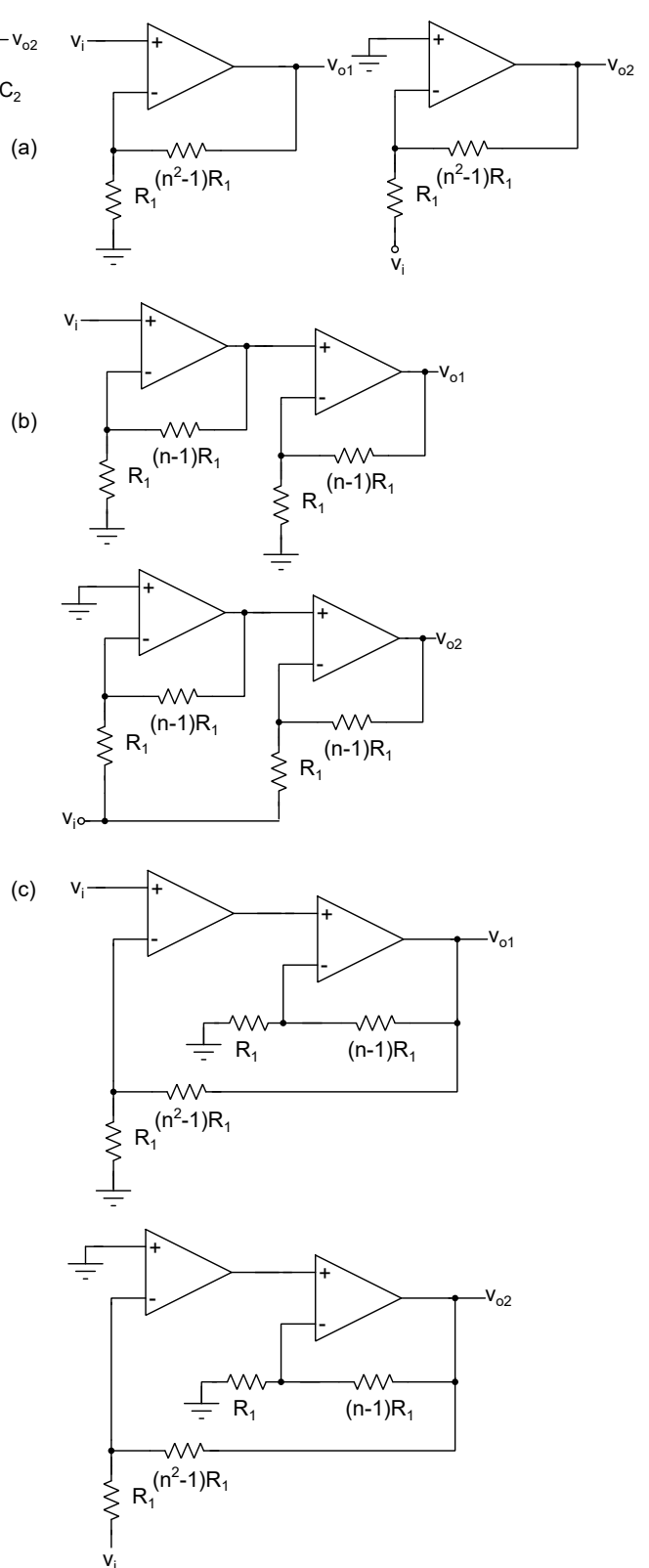

Figure 18: Circuit for Problem 18.

The opamps are ideal. For each of the networks in parts (a), (b) and (c) above, determine $H_1 = v_{o1}/v_i$ and $H_2(s) = v_{o2}/v_i$. Is there a pattern you notice?

Recall that the ideal opamp is a VCVS with infinite

gain and one of its output terminals grounded and inaccessible. How is it that the pattern of Problem 15 holds here, though not in Problem 16?

Problem 19

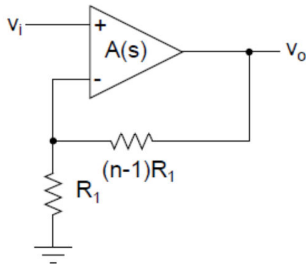

Figure 19: Circuit for Problem 19.

In class, we first assumed that the opamp was a VCVS with infinite gain. We then said – well, in reality, the gain is not infinite, but a large number. In either case, the VCVS had no “memory”, meaning that it is infinitely quick; a change in the input is instantly reflected in the output.

Not surprisingly, it turns out that the opamp is not infinitely fast either. We now, therefore, need to talk about the **transfer function** $V_o(s)/V_i(s)$. This problem will explore the effect of the “slowness” of the opamp on the feedback system. Recall from your prior classes that, for a system to be stable, its poles must be in the left half s -plane.

- For $A(s) = \frac{A_o}{1 + \frac{s}{\omega_o}}$, determine the closed-loop transfer function $V_o(s)/V_i(s)$. Determine the 3-dB bandwidth of the loop-gain function. Also determine the 3-dB bandwidth of the closed loop amplifier. How is it related to that of the loop-gain? Plot the locus of the poles of the closed loop system as A_o is varied from $0 - \infty$. Comment on the stability of the closed-loop system.
- Let us assume a more complicated model for $A(s)$. Let $A(s) = \frac{A_o}{(1 + \frac{s}{\omega_o})^2}$. Determine the closed-loop transfer function $V_o(s)/V_i(s)$. Express the transfer function in the form

$$\frac{V_o(s)}{V_i(s)} = \frac{G}{\frac{s^2}{\omega_p^2} + \frac{s}{Q_p \omega_p} + 1}, \quad (2)$$

where G is the dc gain. Plot the locus of the poles of the closed loop system as A_o is varied from $0 - \infty$. Comment on the stability of the closed-loop system.

- Let us assume an even more complicated model for $A(s)$. Let $A(s) = \frac{A_o}{(1 + \frac{s}{\omega_o})^3}$. Determine the closed-loop transfer function $V_o(s)/V_i(s)$. Plot the locus of the poles of the closed loop system as A_o is varied from $0 - \infty$. Comment on the stability of the closed-loop system.

Problem 20: LTSpice Simulation

- Design the circuit shown in figure 2 in LTSpice using ideal op-amp and observe the output when a sinusoidal input of amplitude 1V and frequency 1kHz is applied at V1, V2 and V3. Verify that $V_o = -(V_1 + V_2 + V_3)$ when $R_1 = R_2 = R_3 = R_4$.
- Design the circuit in figure 3 with real op-amp (supply limited) observe V_o when a triangular waveform of 1kHz as show in figure is applied at Vi. Vary amplitude of the triangular wave from 1V to 5V with step of 1V and observe the output. Find the maximum amplitude which can be applied at Vi for distortion free output (V_o is not saturated).