

Serializer;

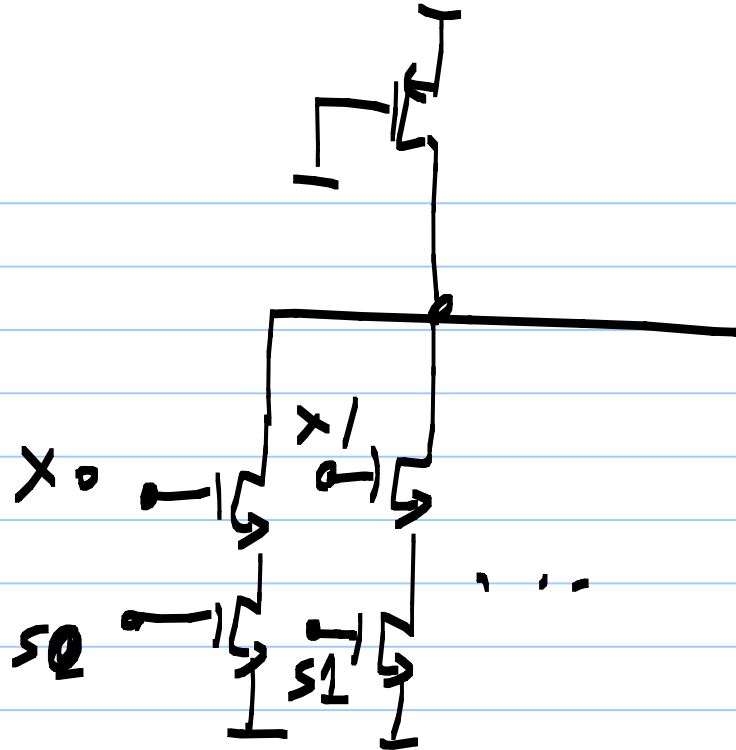

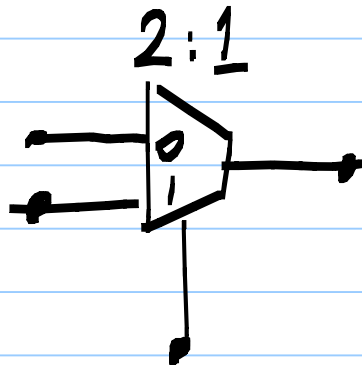

Deserializer:

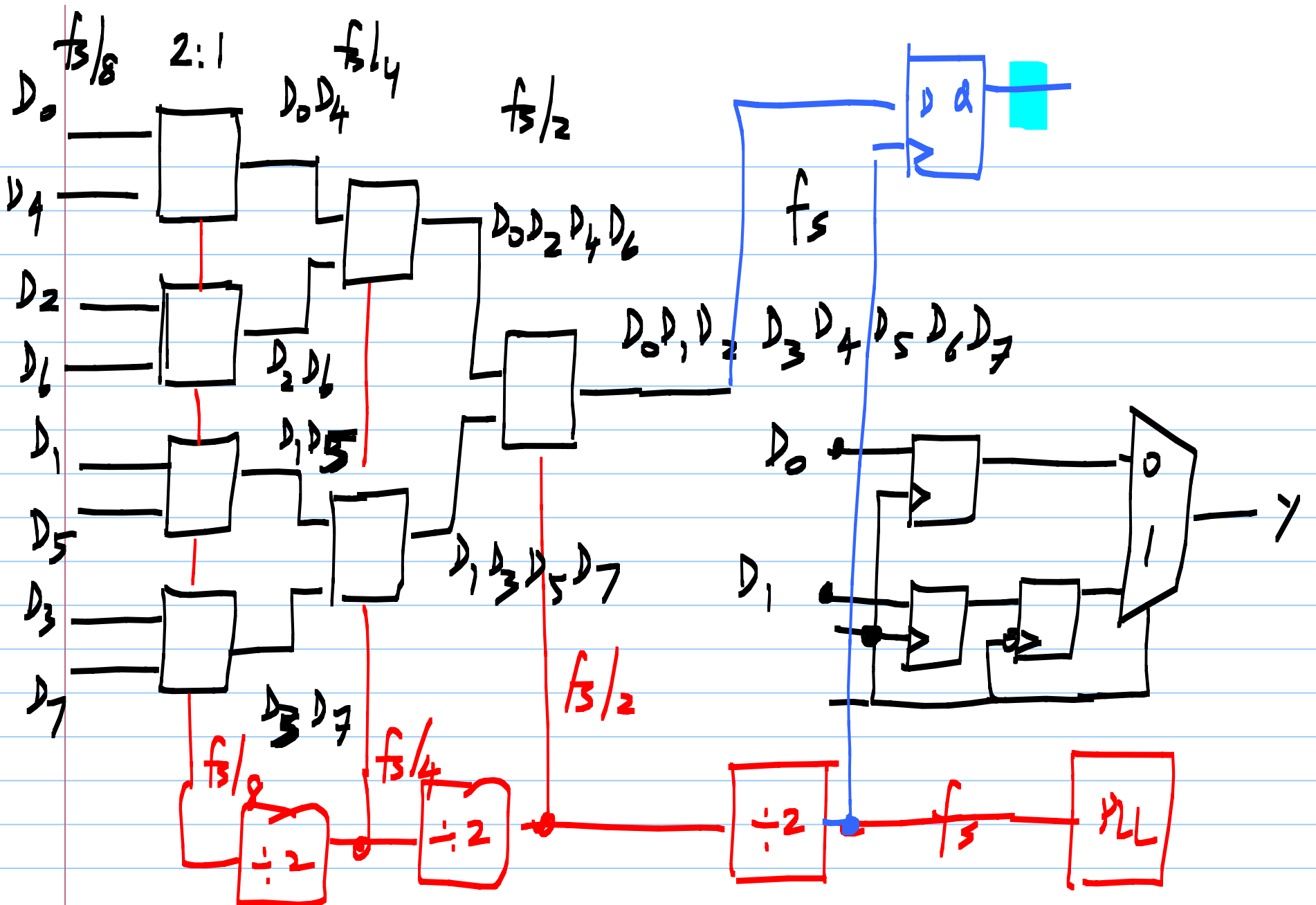
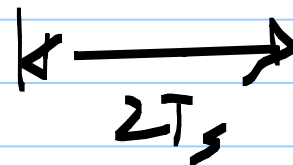
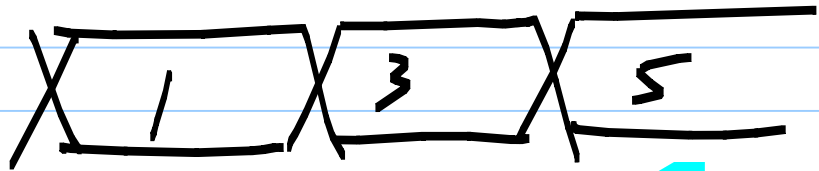
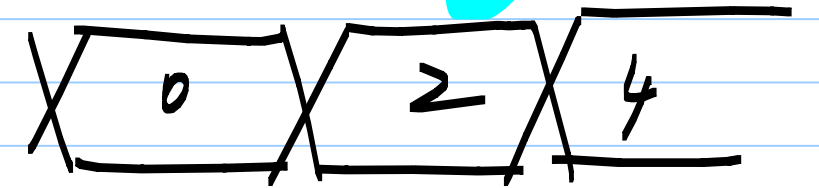
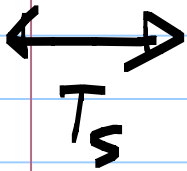
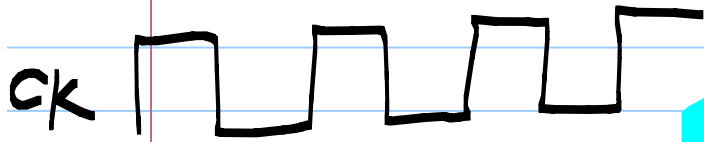
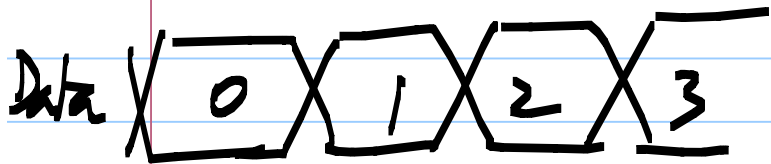
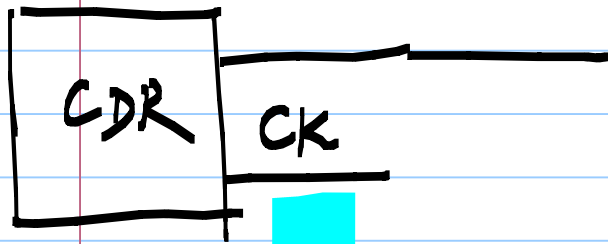

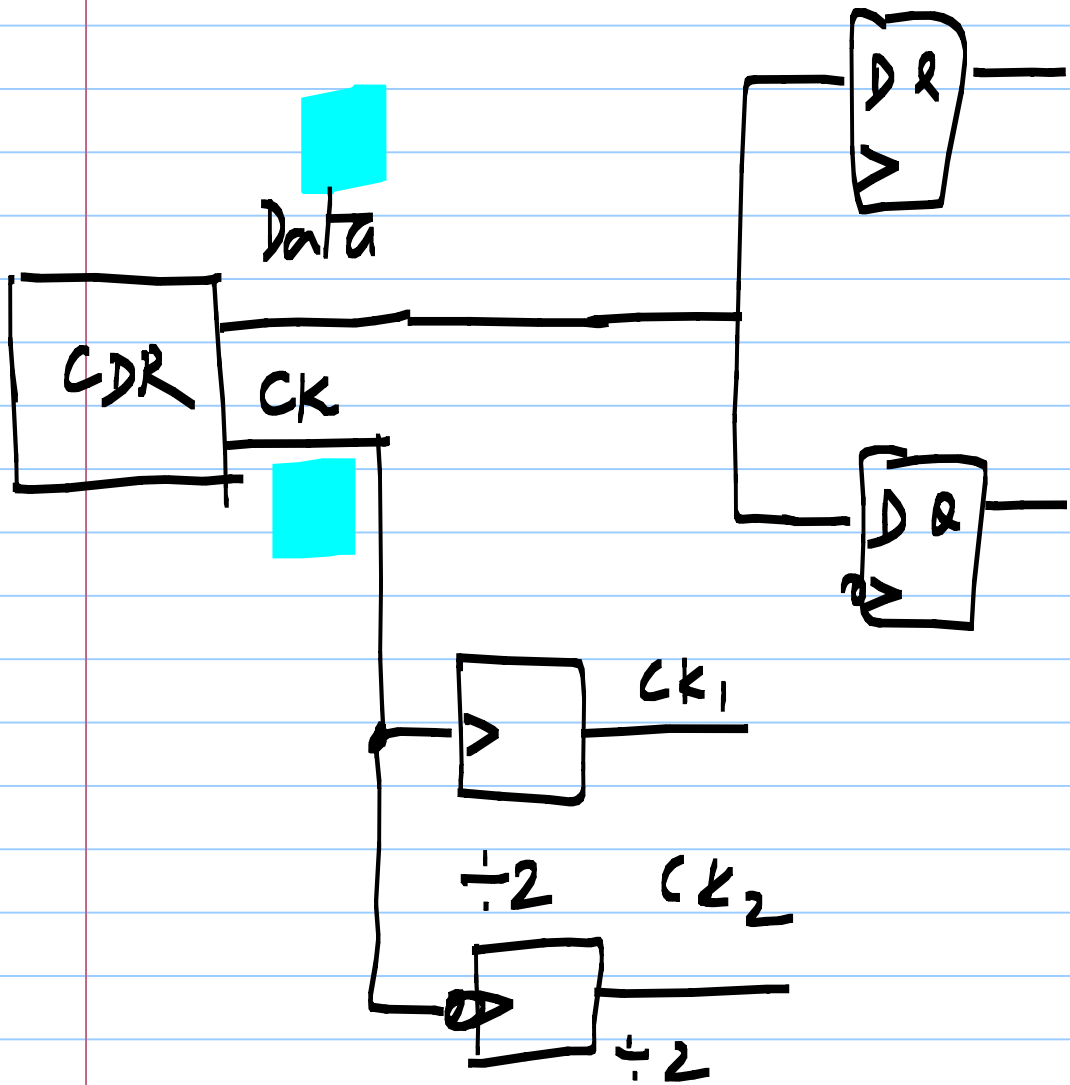

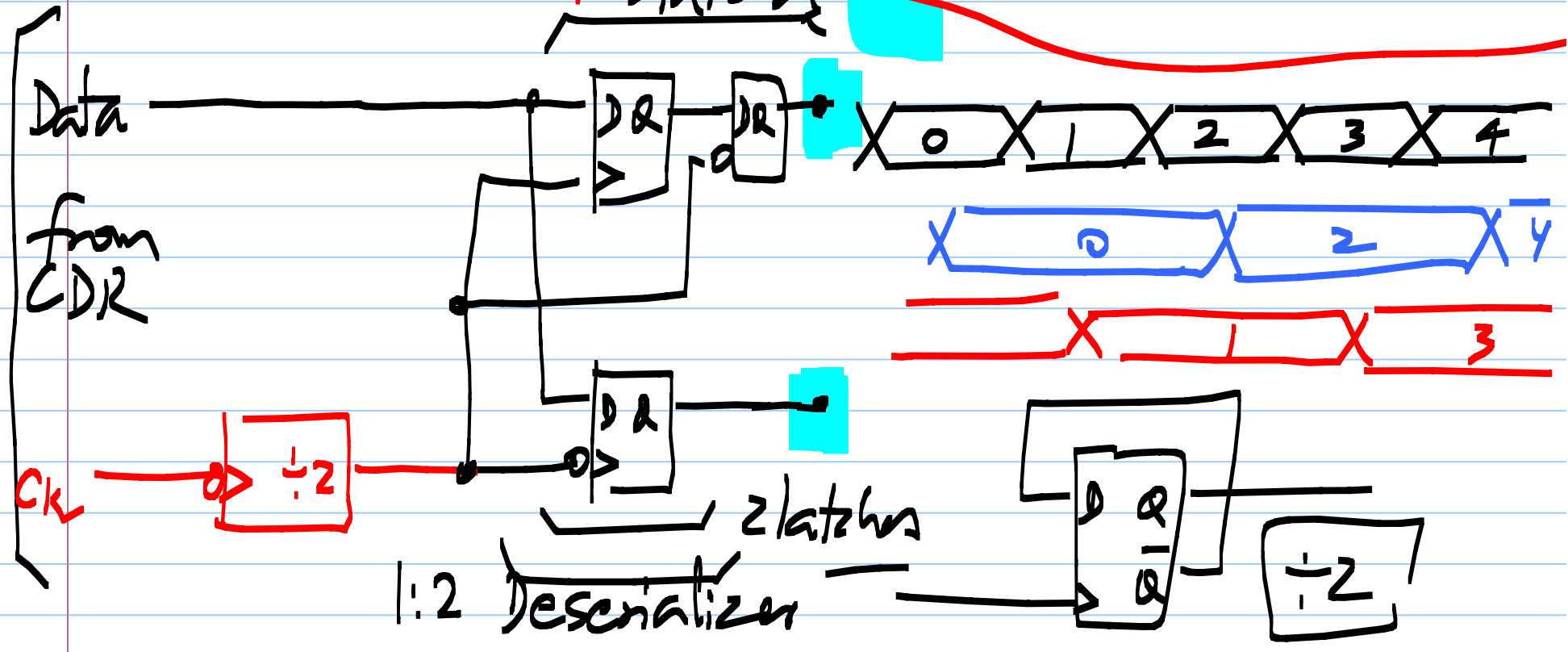
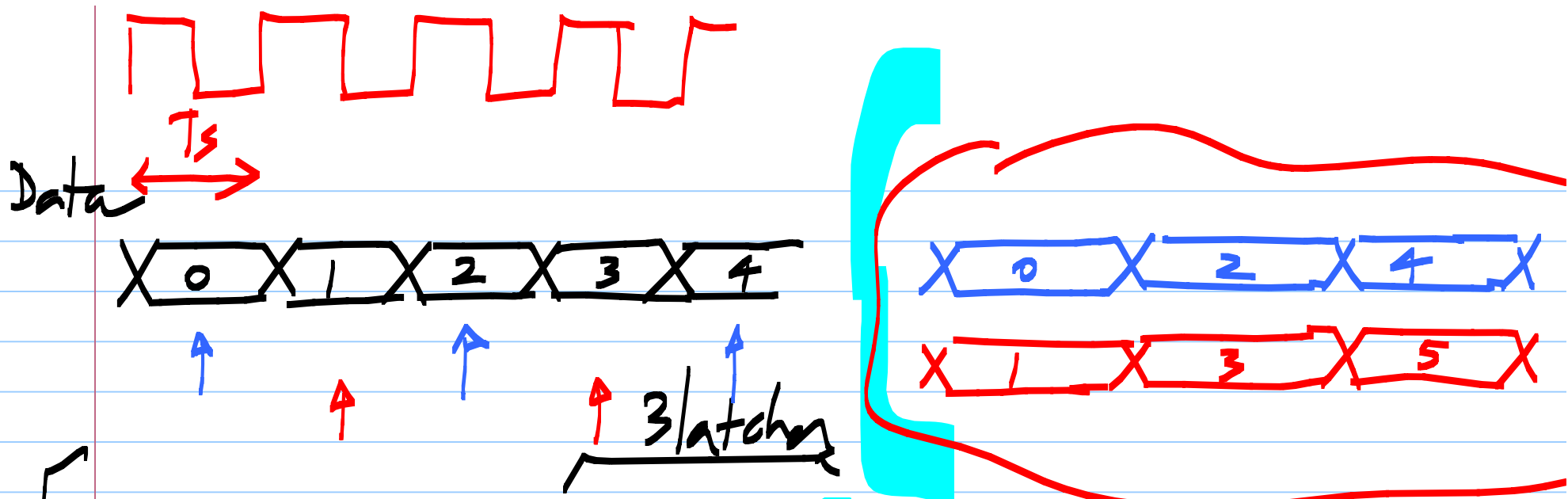

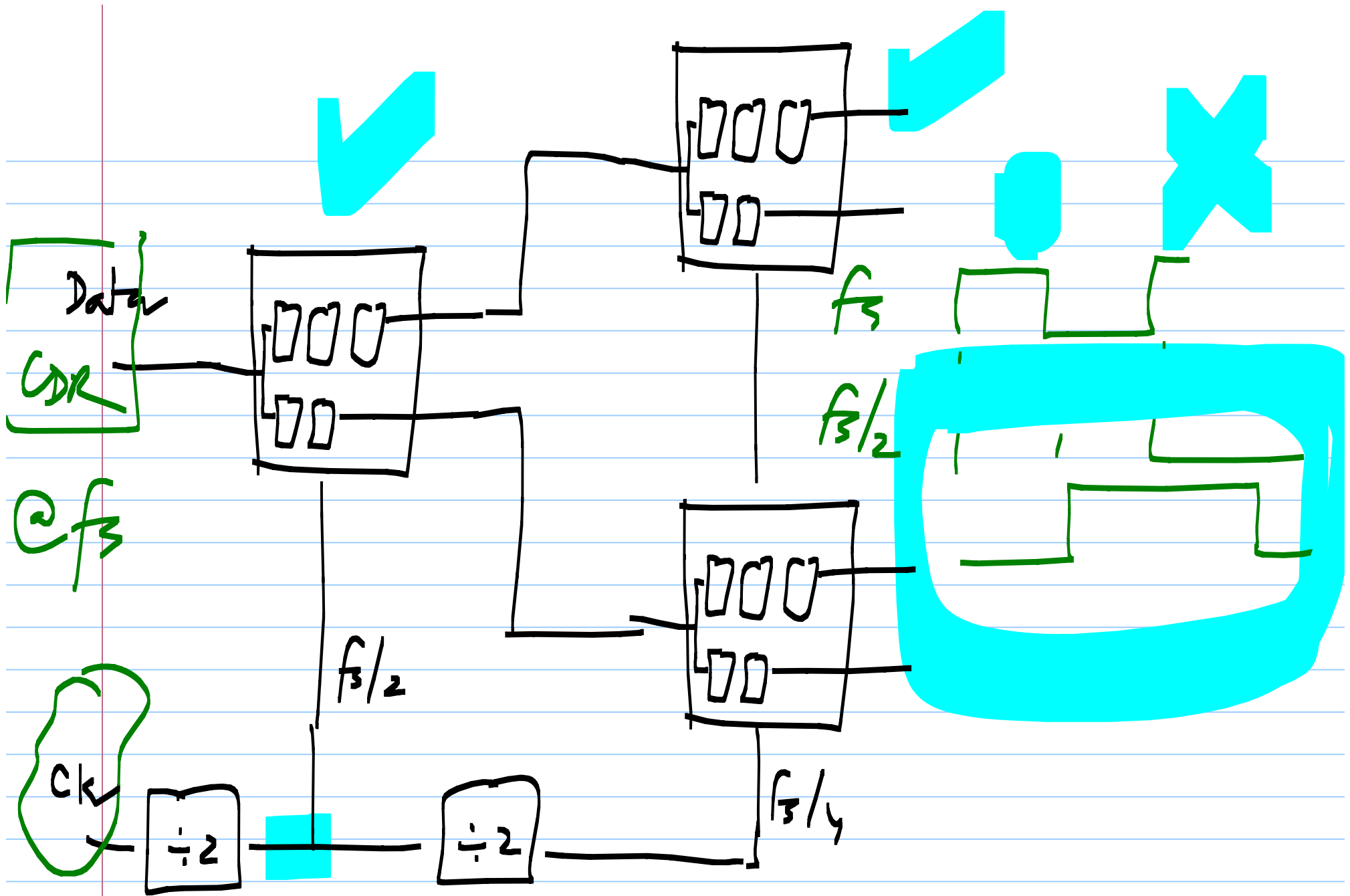

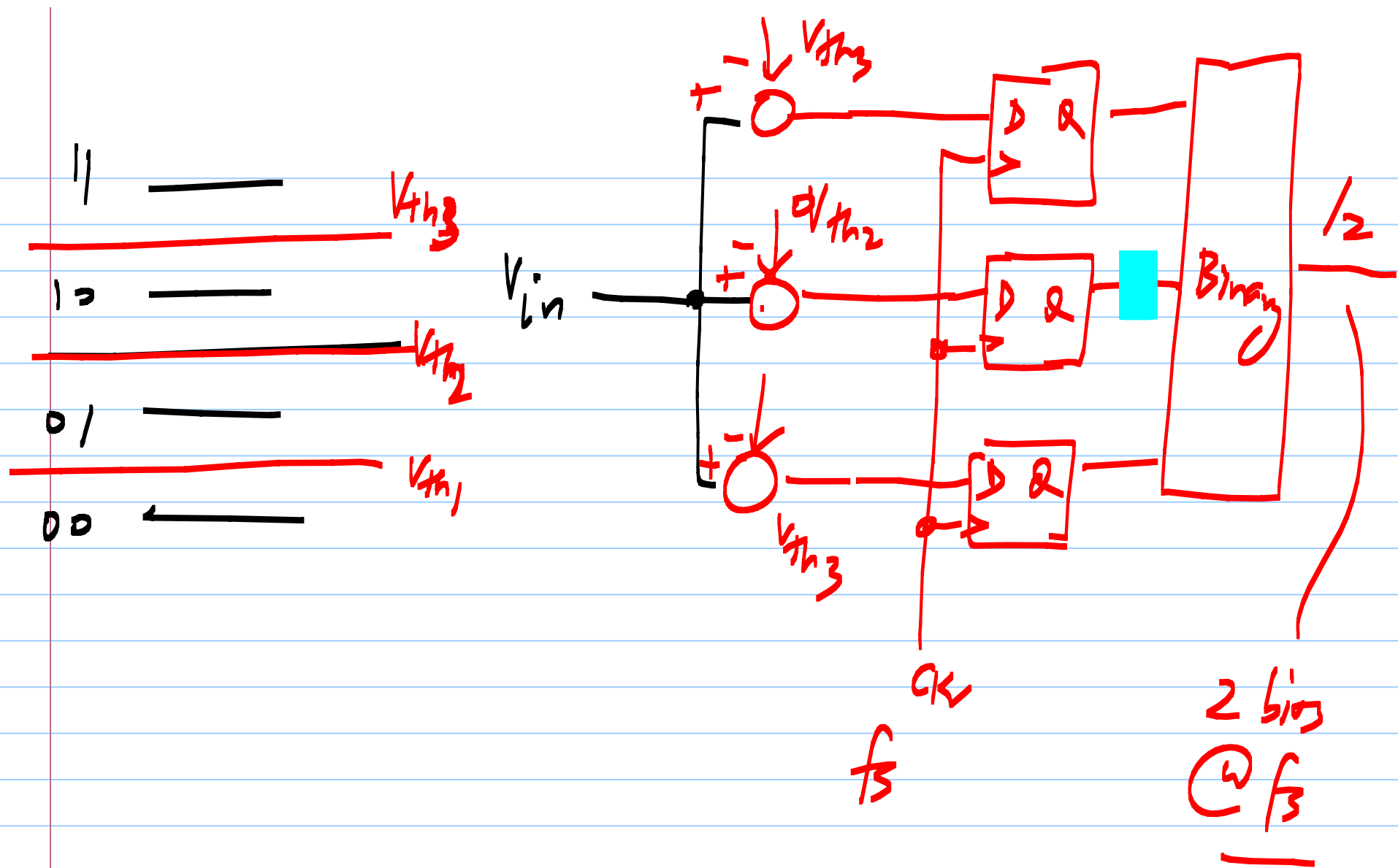

f_3
=

$$\frac{BW}{f_0} \ll 1$$

