

# EE2019: Analog Systems and Lab

## Introduction

Nagendra Krishnapura  
Qadeer Ahmad Qhan  
Saurabh Saxena  
Shanthi Pavan

<https://courses.iitm.ac.in>

Department of Electrical Engineering  
Indian Institute of Technology, Madras  
Chennai, 600036, India

16 January 2018

# Outline

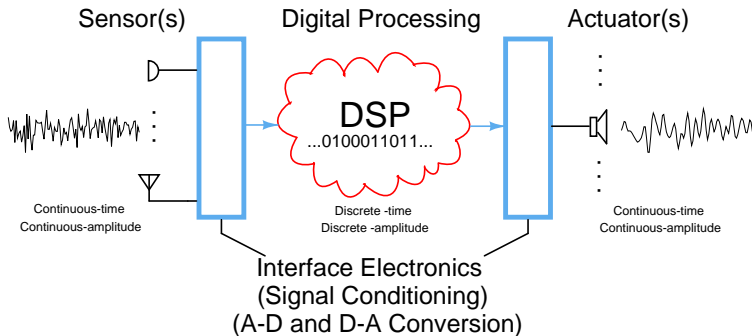

courtesy Shanthi Pavan

Picture:

# Analog circuits in modern systems on VLSI chips

- Analog to digital conversion
- Digital to analog conversion
- Amplification
- Signal processing circuits at high frequencies
- **Power management-voltage references, voltage regulators**
- **Oscillators**

The last two are found even on many “digital” ICs

# Analog IC design in India

- Many companies starting analog centers
- Multinationals and Indian start ups
- Big demand for skilled designers
- Interesting and profitable activity 😊

## Theory and Lab

- Negative feedback systems and their building blocks
- Stabilization of feedback circuits
- Applications

# Course goals

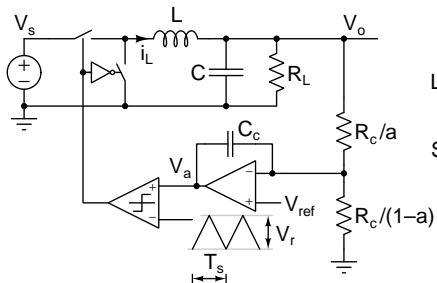

$$L(s) = \frac{a}{sC_c R_c} \frac{V_s}{V_r} \frac{1}{s^2 LC + sL/R + 1}$$

Steady state  $V_o = V_{ref}/a$

# Course prerequisites

- Circuit analysis
  - Mesh, nodal analyses
  - RLC, linear dependent sources
- Laplace transforms, frequency response
- Differential equations
- Basic digital logic gates

EE1101: Signals and Systems

EE2015: Electric Circuits and Networks

EE2001: Digital Systems and Lab

# Course contents

- Controlled sources
- Realizing accurate transfer characteristics using negative feedback
- Stabilization of negative feedback systems
- Negative feedback amplifiers
- DC-DC converters
- Filters
- Oscillators
- Track-and-hold, ADC, DAC
- ...



- EE3002: Analog circuits
- EE3703: Analog circuits lab
- EE5390: Analog IC design
  
- EE5323: Advanced Electrical Networks
- EE534: Active Filter Design
- EE6320: RF Integrated Circuits
- EE6321: VLSI Data Conversion Circuits
- EE6322: VLSI Broadband Communication Circuits
- EE6323: Wireless System Design
- EE6324: Phase-Locked Loops
- EE5325: VLSI Power Management Circuits

## Course homepage

- IITM moodle: <https://courses.iitm.ac.in/>
- [http://www.ee.iitm.ac.in/vlsi/ee2019\\_2018/start](http://www.ee.iitm.ac.in/vlsi/ee2019_2018/start)

## Recorded lectures

- <http://www.ee.iitm.ac.in/~nagendra/videolectures/>

## Text book

- None

## References

- A. S. Sedra and K. C. Smith, *Microelectronic Circuits*, 5ed, Oxford University Press, 2004.
- Sergio Franco, *Design with operational amplifiers and analog ICs*, Tata McGraw Hill.
- Hayt and Kemmerly, *Engineering Circuit Analysis*, McGraw Hill, 6/e.
- B. P. Lathi, *Linear Systems and Signals*, Oxford University Press, 2 edition, 2004.

- E slot (Odd roll numbers: ESB127; Even roll numbers: ESB106)
- Extended tutorial: Thursday, 9am-12pm, IE labs
- Lab: T slot, Friday, 2pm-445pm, IE labs

# Etiquette and expectations

- Mobile phones off
- 85% attendance (includes tutorial sessions, excludes quizzes)
- Don't enter the class if more than 5 minutes late
- TAs take attendance in the first 5 minutes
  - Bring your ID cards for attendance
- **Must** solve problems given in classes

# Must know or refresh

- Basic circuit analysis (nodal/mesh analysis)
- Bode plots
- Two port parameters
- Differential equations and time domain solutions
- Circuit analysis with Laplace transforms

(Links to recorded lectures on the webpage)

# Evaluation

- 4 quizzes-35%
- End sem-30%
- Lab-25%
- Tutorials-10%
  - Must attend. Marks based on number of problems solved completely.

# Teaching assistants

Post any questions related to the course on the moodle forum  
TAs will be at: DSD lab(ESB 122) or VLSI group labs(CSD 204, 206)  
Office hours will be announced



# For more advanced students

Simulate the circuits you see in class

- <http://www.ee.iitm.ac.in/~nagendra/cadinfo.html>
- Online spice simulator at <http://www.ngspice.com/index.php>

Build the circuits

- Breadboard, components, IE lab