

EC5135: Analog Electronic Circuits

EC3102: Analog Circuits

Introduction

Aniruddhan S
Nagendra Krishnapura

<https://courses.iitm.ac.in>

Department of Electrical Engineering
Indian Institute of Technology, Madras
Chennai, 600036, India

31 July 2012

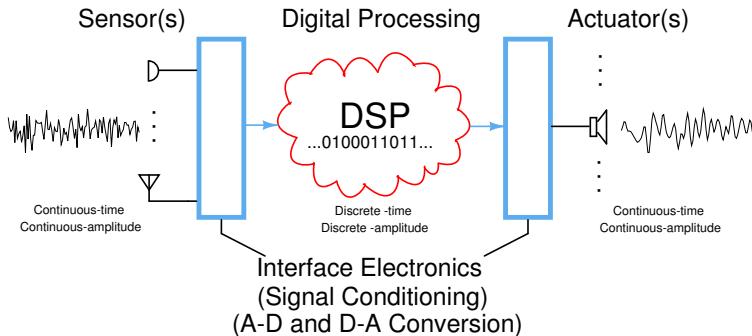

Picture: courtesy Shanthy Pavan

Analog circuits in modern systems on VLSI chips

- Analog to digital conversion
- Digital to analog conversion
- Amplification
- Signal processing circuits at high frequencies
- **Power management-voltage references, voltage regulators**
- **Oscillators**

The last two are found even on many “digital” ICs

Analog IC design in India

- Many companies starting analog centers
- Multinationals-TI, ST, ADI etc.
- Indian start ups-Cosmic, Karmic, Sankalp etc.
- Big demand for skilled designers
- Interesting and profitable activity 😊

Theory

- Small signal analysis of nonlinear systems
- Analysis of nonlinearity and frequency response
- Stabilization of feedback circuits

Design

- Amplifier topologies
- Biasing techniques

Course goals

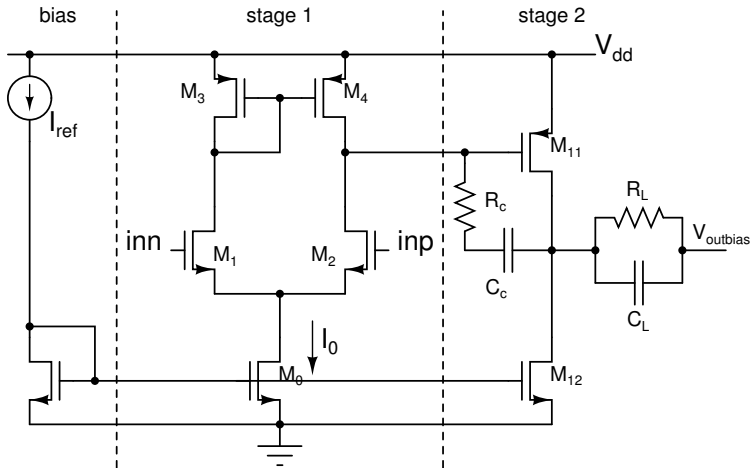

Course prerequisites

- Circuit analysis
 - Mesh, nodal analyses
 - RLC, linear dependent sources
- Laplace transforms, frequency response
- Differential equations

EC1010: Electrical and Magnetic Circuits

EC2102: Networks and Systems

Course contents

- Nonlinear circuits-incremental analysis
- Obtaining power gain; MOS transistor
- Amplifiers with MOS and BJTs
- Opamps, negative feedback, stability
- Applications: Active filter, voltage regulator

Follow up

- EC3300: Analog circuits lab
- EE5390: Analog IC design

- EE5340: Active filter design
- EE6580: VLSI data conversion circuits
- EE6850: VLSI broadband communication circuits
- EE6240: RF integrated circuits

Course homepage

- IITM moodle: <https://courses.iitm.ac.in/>
- http://www.ee.iitm.ac.in/vlsi/ec3102_2012/start

Recorded lectures

- <http://www.ee.iitm.ac.in/~nagendra/videolectures/>
- Lectures recorded in the classroom
- KRK Rao foundation on Analog Design, June 2008: (Review of basic concepts: Network analysis, small signal analysis, Transistor models, Negative feedback)
- NPTEL—Prof. VGK Murti's *Networks and Systems*, and other courses on circuit analysis.

Text book

- None

References

- A. S. Sedra and K. C. Smith, *Microelectronic Circuits*, 5ed, Oxford University Press, 2004.
- Sergio Franco, *Design with operational amplifiers and analog ICs*, Tata McGraw Hill.
- Hayt and Kemmerly, *Engineering Circuit Analysis*, McGraw Hill, 6/e.
- B. P. Lathi, *Linear Systems and Signals*, Oxford University Press, 2 edition, 2004.
- N. Krishnapura, "Introduction of EE539", <http://www.ee.iitm.ac.in/~nagendra/EE539/200801/handouts.html>

- E slot
- Odd roll numbers-ESB127, Even roll numbers-ESB106

Etiquette and expectations

- Mobile phones off
- 85% attendance
- Don't enter the class if more than 5 minutes late
- TAs take attendance in the first 5 minutes
- **Must** solve problems given in classes

Evaluation

- 4 quizzes-50 to 60%
- End sem-40%
- Problem sets on the course website-up to 10%

Teaching assistants

- Animesh Paul
- Anoop M K
- Avinash Merugu
- Chavva Anusha
- Imon Mondal
- Madhukar Vallabhaneni
- Rahul Kumar
- Sanak N K
- Sandeep S.K.
- Sudharshan V
- Sukhavasi Manoj
- Sumit Kumar
- Sreejith P. Das
- Vikas Kumar S

Post any questions related to the course on the moodle forum
TAs will be at: DSD lab(ESB 122) or VLSI group labs(CSD 204,
206)

For more advanced students

Simulate the circuits you see in class

- <http://www.ee.iitm.ac.in/~nagendra/cadinfo.html>

Build the circuits

- Breadboard, components, IE lab