

EE5390 Analog Integrated Circuit Design
Assignment 2

Friday, March 07, 2014

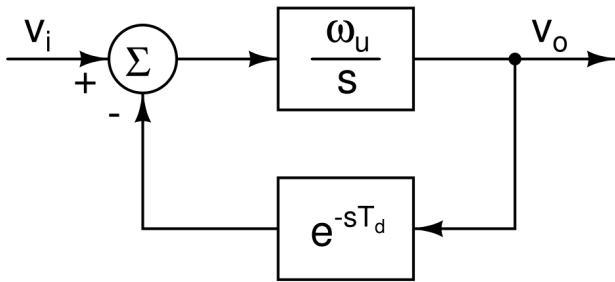

Figure 1: Problem 1

1. (a) Setup the differential equation for the system above.

(b) V_i is 1V for a long time and changes to 0V at $t = 0$. What is the equation for $t > 0$?

(c) Assume that the solution is of the form $V_p \exp(\sigma t)$. Obtain the equation from which you will determine σ (You are not required to solve it analytically).

(d) Express the above equation as $f(\sigma) = 0$. Sketch $f(\sigma)$. Determine the extremum of $f(\sigma)$ in terms of T_d . For what value of T_d does the extremum become equal to zero? Plot the curves in Matlab and show the solutions.

(e) Assume that the solution is of the form $V_p \exp((\sigma + j\omega)t)$. Obtain the equations from which you will determine σ and ω (You are not required to solve them). Plot the curves in Matlab and show the solutions.

(f) Reduce the above to a single equation in ω .

2) Fig. 2(a) shows a nonlinearity f enclosed in a negative feedback loop with a feedback fraction β . Fig. 2(b) shows a nonlinearity f preceded by an attenuation factor.

(a) In each case, denote the transfer characteristic of the overall system by g , i.e. $V_o = g(V_i)$ and calculate the first three terms of the Taylor series of g about the operating point of the circuit in terms of f and its derivatives. Assume that $f(0) = 0$.

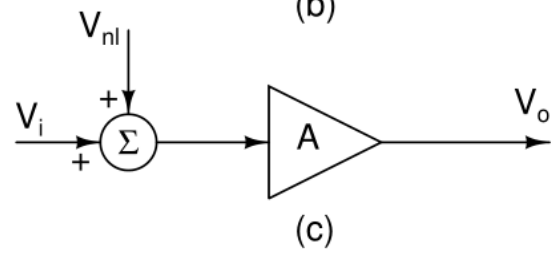
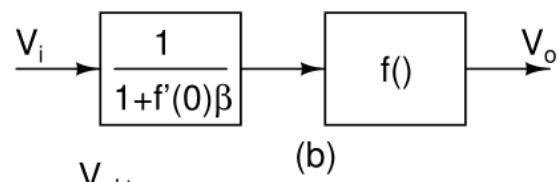
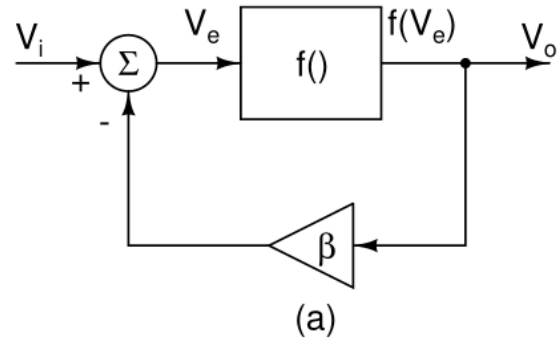

Figure 2: Problem 2

(b) Fig. 2(c) shows the linear small signal equivalent circuit from V_i to V_o with an additional input V_{nl} . For the systems in Fig. 2(a) and Fig. 2(b), compute the small signal equivalent gain A and the additional input V_{nl} . What do you infer from the results?