

# ANALOG SYSTEMS : PROBLEM SET 1

## Problem 1

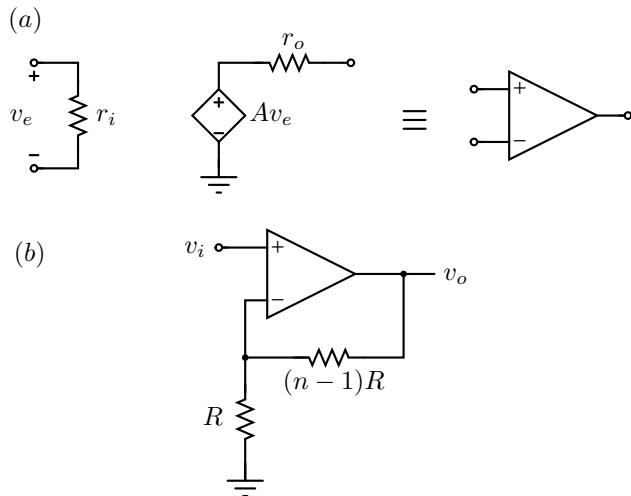

Figure 1: (a) Simplified equivalent circuit of a VCVS, with a large  $A$ . (b) The VCVS embedded in a negative feedback loop.

In class, we saw how a VCVS with a large but imprecise gain can be embedded inside a negative feedback loop to realize a VCVS with a stable gain. It turns out that in practice, the imprecise VCVS, shown in Fig. 1(a), is not all that ideal – its input resistance is finite, and its output resistance is non-zero. The symbol for the imprecise VCVS is also shown in Fig. 1(a). It is realized to make the VCVS shown in Fig. 1(b). If  $A = \infty$ ,  $v_o/v_i = n$ .

Determine the input resistance, gain and output resistance of the VCVS of Fig. 1(b) in terms of  $A$ ,  $r_i$ ,  $r_o$ ,  $R$  and  $n$ .

Evaluate the quantities above under the following limiting conditions.

- a. Input resistance and gain when  $r_o = 0$ .
- b. Output resistance and gain when  $r_i = \infty$ .
- c.  $A \rightarrow \infty$ .

## Problem 2

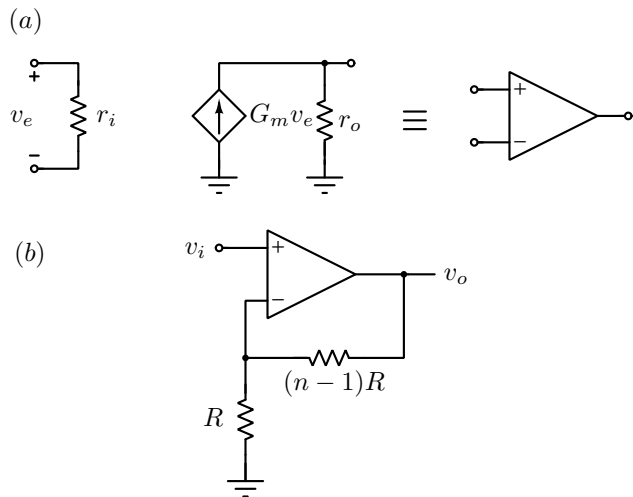

Figure 2: (a) Simplified equivalent circuit of a VCCS, with a large  $G_m$ . (b) The VCCS embedded in a negative feedback loop.

Rather than use a VCVS with a large (but uncertain) gain, this problem attempts to use a VCCS with a large (but uncertain) transconductance  $G_m$ . Further, the imprecise VCCS, shown in Fig. 2(a), is not all that ideal – its input and output resistances are finite. For simplicity, we use the same symbol for the imprecise VCCS as in Fig. 1(a). It is realized to make the VCVS shown in Fig. 2(b). What is  $v_o/v_i$  when  $G_m = \infty$ ?

Determine the input resistance, gain and output resistance of the VCVS of Fig. 2(b) in terms of  $G_m$ ,  $r_i$ ,  $r_o$ ,  $R$  and  $n$ .

Evaluate the quantities above under the following limiting conditions.

- a. Input resistance and gain when  $r_o = \infty$ .
- b. Output resistance and gain when  $r_i = \infty$ .
- c.  $A \rightarrow \infty$ .