

# EC201-ANALOG CIRCUITS : PROBLEM SET 4

shanthi@ee.iitm.ac.in

## Problem 1

The circuit of Fig. 1 shows an amplifier.

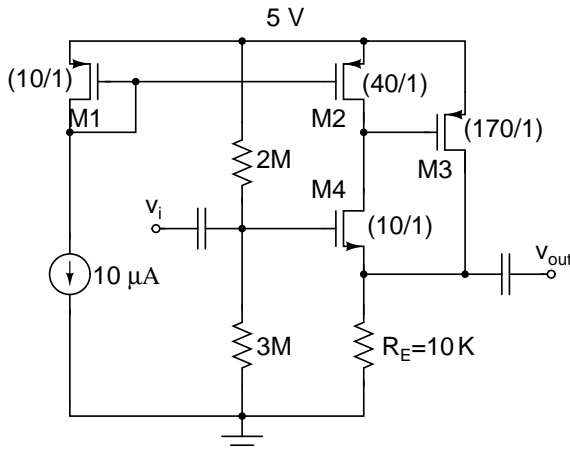

$$V_{Tn}=0.7V, \mu_n C_{ox}=200\mu A/V^2$$

$$|V_{Tp}|=0.8V, \mu_p C_{ox}=50\mu A/V^2$$

Figure 1: Problem 1

- Determine the operating points of all the devices in the circuit. For this part, assume  $\lambda = 0$  for all devices.
- All transistors have finite output impedance, such that for any transistor,  $g_m r_o = 100$ . Draw the small signal equivalent circuit of the amplifier. Determine the small signal gain from  $v_i$  to  $v_{out}$  and the input and output resistances of the amplifier.
- Determine the amplitude of the largest sinusoid that can be applied at the input, so that the output is also a sinusoid, devoid of clipping effects. As usual, assume that the coupling capacitors are infinite.

## Problem 2

The circuit of Fig. 2 shows a common-drain amplifier.

- Determine the operating points of all the devices in the circuit. For this part, assume  $\lambda = 0$  for all devices.
- All transistors have finite output impedance, such that for any transistor,  $g_m r_o = 100$ . Draw the small signal equivalent circuit of the amplifier. Determine the small signal gain from  $v_i$  to  $v_{out}$  and the input and output resistances of the amplifier.

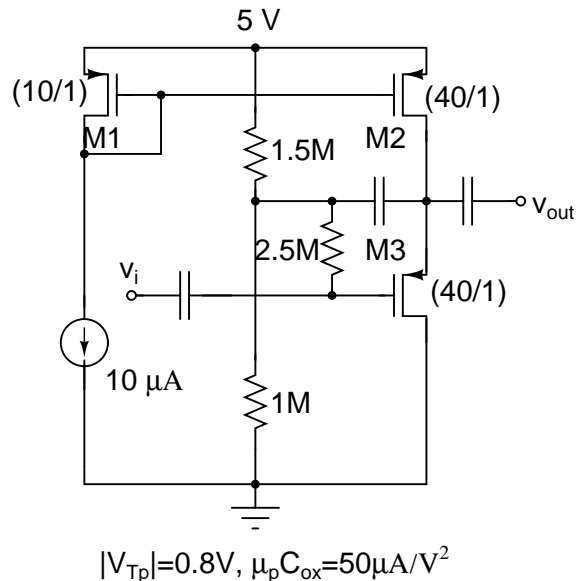

$$|V_{Tp}|=0.8V, \mu_p C_{ox}=50\mu A/V^2$$

Figure 2: Problem 2

- Determine the amplitude of the largest sinusoid that can be applied at the input, so that the output is also a sinusoid, devoid of clipping effects. As usual, assume that the coupling capacitors are infinite.

## Problem 3

The circuit of Fig. 3 shows an amplifier.

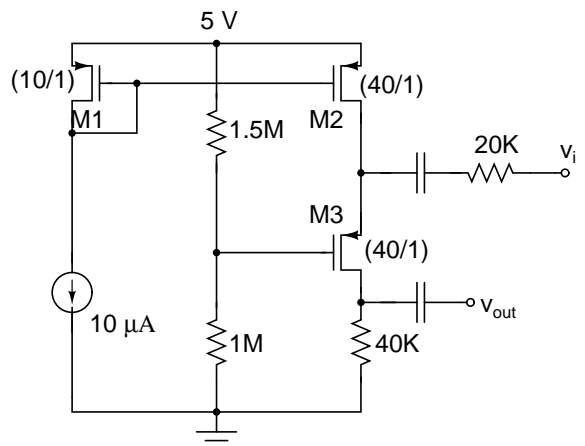

$$|V_{Tp}|=0.8V, \mu_p C_{ox}=50\mu A/V^2$$

Figure 3: Problem 3

- Determine the operating points of all the devices in the circuit. For this part, assume  $\lambda = 0$  for all devices.

- All transistors have finite output impedance, such that for any transistor,  $g_m r_o = 100$ . Draw the small signal equivalent circuit of the amplifier. Determine the small signal gain from  $v_i$  to  $v_{out}$  and the input and output resistances of the amplifier.
- Determine the amplitude of the largest sinusoid that can be applied at the input, so that the output is also a sinusoid, devoid of clipping effects. As usual, assume that the coupling capacitors are infinite.

### Problem 4

In the circuit of Fig. 4, assume that all devices operate in saturation.

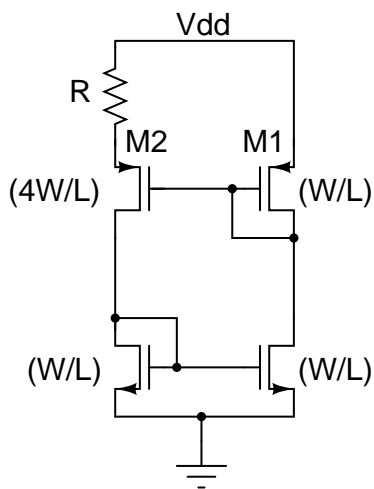

Figure 4: Problem 4

- Determine the operating points of all the devices in the circuit. Assume  $\lambda = 0$  for all devices. The answers should be in terms of  $|V_{TP}|$ ,  $V_{TN}$ ,  $\mu_n C_{ox}$ ,  $\mu_p C_{ox}$ ,  $R$ ,  $V_{dd}$  &  $(W/L)$ .
- What is the transconductance of M1? How does it depend on the device thresholds,  $\mu_n C_{ox}$  and  $\mu_p C_{ox}$ ? What do you think the practical utility of this circuit is?
- Determine the minimum  $V_{dd}$  required to ensure that all devices are in saturation.

### Problem 5

The circuit of Fig. 5 shows an amplifier.

- Determine the operating points of all the devices in the circuit. For this part, assume  $\lambda = 0$  for all devices.
- All transistors have finite output impedance, such that for any transistor,  $g_m r_o = 100$ . Draw the small signal equivalent circuit of the amplifier. Determine the input and output resistances of the amplifier. What kind of controlled source is this? Determine the relevant "transfer" parameter of the source.

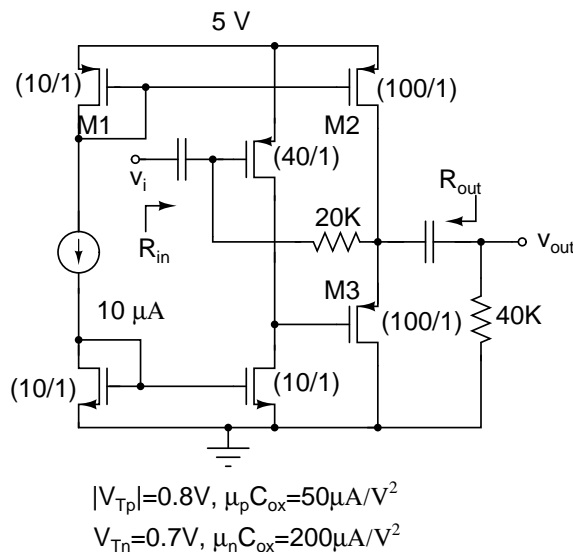

Figure 5: Problem 5

- Determine the amplitude of the largest sinusoid current at the input, so that the output is also a sinusoid, devoid of clipping effects. As usual, assume that the coupling capacitors are infinite.

### Problem 6

In the circuit of Fig. 6, determine the voltages at  $V_a$  and  $V_b$ . Neglect  $\lambda$ . For the transistors, use same the device parameters as in Problem 1.

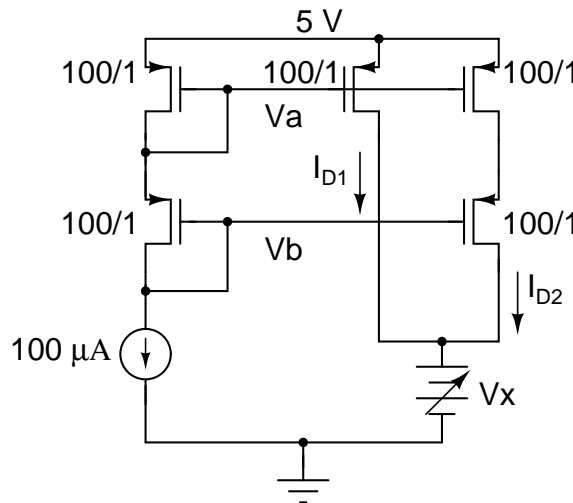

Figure 6: Problem 6

- Assume that  $\lambda = 0$ . Plot  $I_{D1}$  and  $I_{D2}$  in the voltage source  $V_x$  is varied in the range 0-to- $V_b + |V_{TP}|$ .
- Repeat the above for  $\lambda = 0.1 V^{-1}$ .